

2024.09.14

Specification

of Tower Combiner Box
(5 clusters)



1. Product introduction

1.1 Product introduction

Tower Combiner Box in the energy storage system is to ensure that the energy storage component orderly connection and the connection device of flow function. Combiner Box can guarantee energy storage system is easy to cut off the circuit when maintenance, inspection, failure occurs when the energy storage system, reduce the scope of the power outage ensure availability of system.

1.2 Product introduction

Item	Unit	Spec
Power supply rated supply voltage	V	24VDC/220VAC
Maximum number of battery clusters supported	/	5
Dimension (W*D*H)	mm	580*480*170
Weight	kg	14
IP Rating	/	IP65
Altitude	m	4000
Operating Temperature	°C	-40~60

2. Basic principles and structures

2.1 Principle block diagram

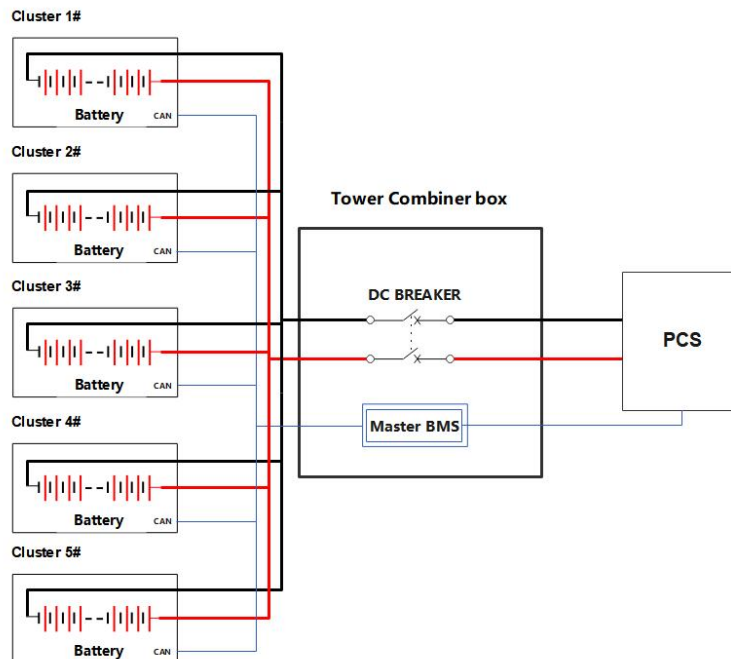

2.2 Working principle

The Combiner box is mainly composed of bus copper bars, switches and boxes. When the switch is closed, the electric cabinet of each branch passes through the copper confluence . The combiner box is connected to the PCS to achieve energy exchange between the battery and the PCS.

2.3 Appearance and Structure

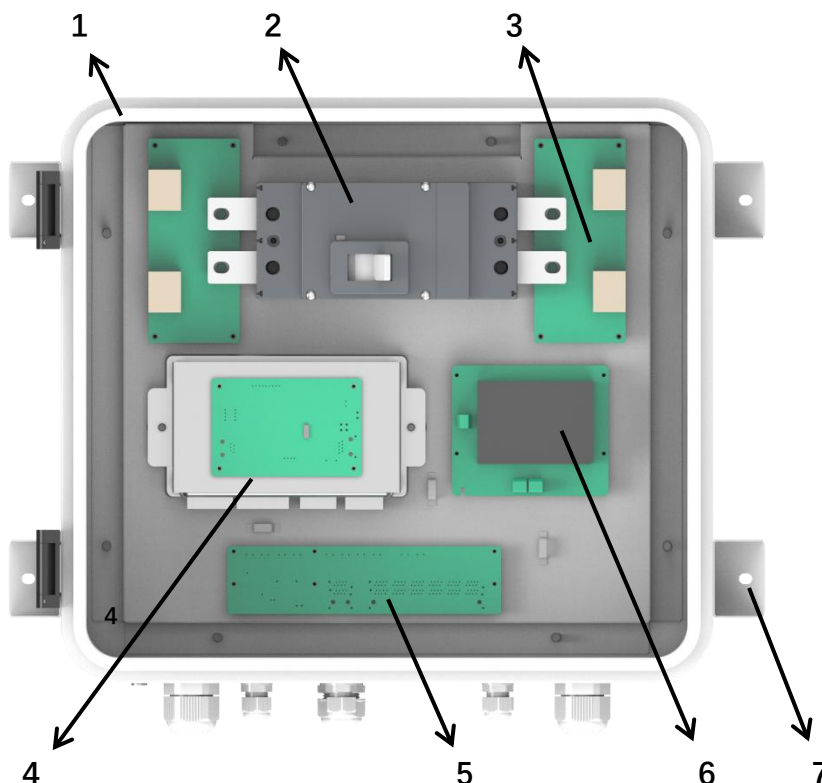

Item	Name	Definition
1	Box	Tower combiner box
2	DC breaker	When the system is operating normally, the DC switch is in the ON position
3	Bus PCB board	Used for summarizing the current of 5 clusters of batteries
4	BMS	The BMS is used to summarize the battery data of each cluster and communicate with the inverter
5	Communication board	Used to summarize the communication data of each cluster of batteries
6	AC/DC	Supply 24V DC power to BMS
7	Installation fixing hole	Used for DC combiner box and wall installation and fixing

2.4 Port Definition

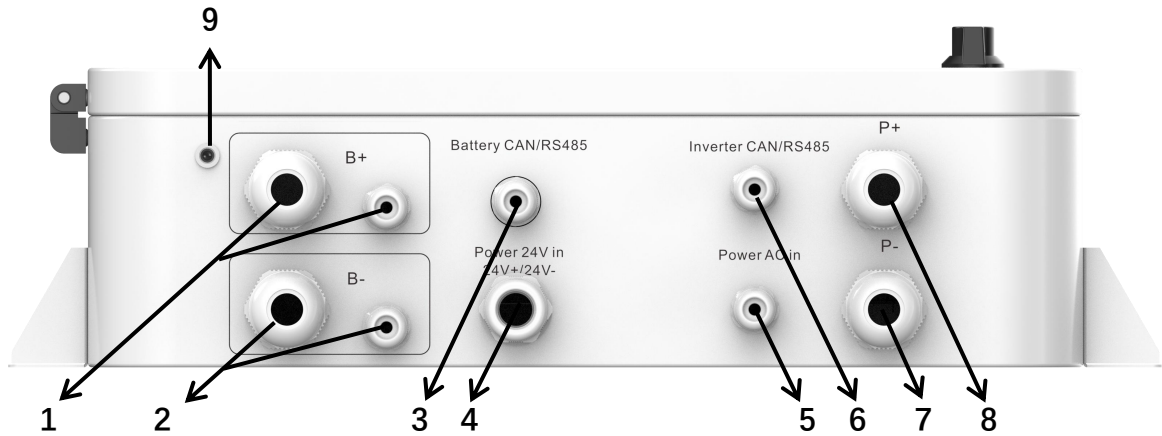

Item	Name	Definition
1	B+	Battery positive power cable interface
2	B-	Battery negative power cable interface
3	Power 24V in	24V DC power cable passes through this point
4	Battery CAN/RS485	Connect the communication cable for each battery 1~5
5	Power AC in	220V AC power cable of the combiner box passes through this point
6	Inverter CAN/RS485	Used for communication with inverters
7	P-	PCS negative power cable interface
8	P+	PCS positive power cable interface
9	GND	Combiner box grounding port

2.5 Communication Port Definition

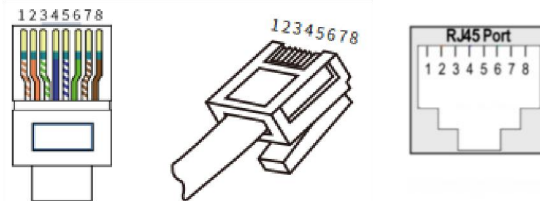

Battery CAN

PIN	Color	Definition
PIN1	Orange/white	NC
PIN2	Orange	NC
PIN3	Green/white	NC

PIN4	Blue	CANH
PIN5	Blue/white	CANL
PIN6	Green	CANIN
PIN7	Brown/white	CANOUT
PIN8	Brown	NC

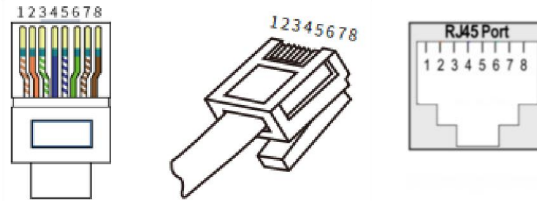

Inverter CAN

PIN	Color	Definition
PIN1	Orange/white	RS485A
PIN2	Orange	RS485B
PIN3	Green/white	NC
PIN4	Blue	CANH
PIN5	Blue/white	CANL
PIN6	Green	NC
PIN7	Brown/white	NC
PIN8	Brown	NC